

Darby Single-hole Basin Faucet
15-01

Installation Instructions



Tools You Will Need



Adjustable Wrench



Adjustable Pliers



Teflon Tape

For ease of installation you will need:

- To read the installation instructions completely before beginning.
- To read all warnings, care, and maintenance information.

Before beginning installation, check for any damage that may have occurred during transport.

Note: Damage claims cannot be made during or after installation.

Installation Instructions

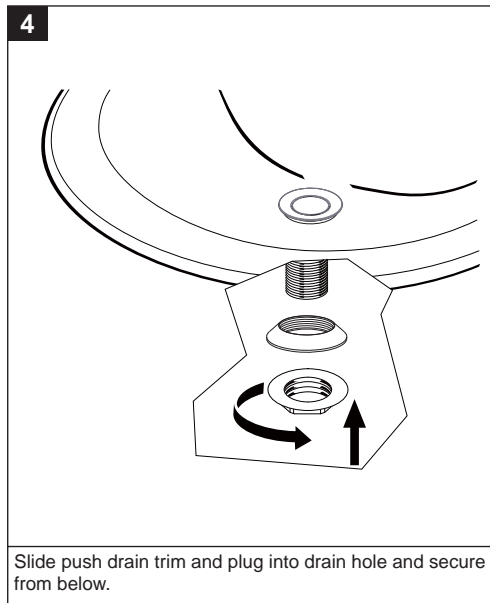
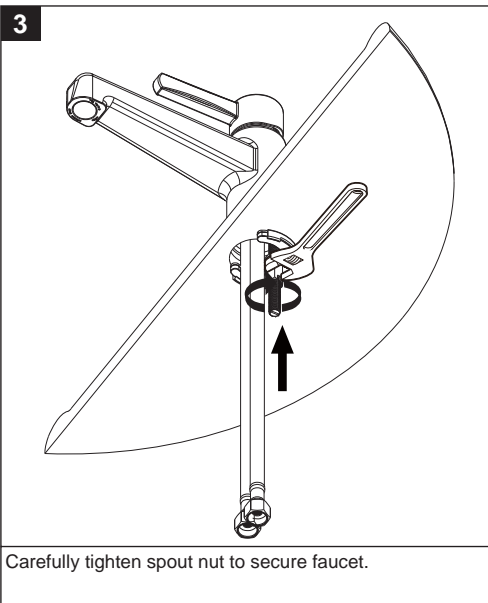
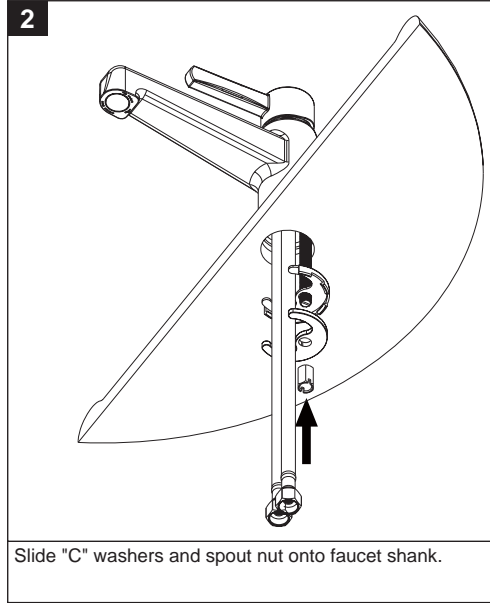
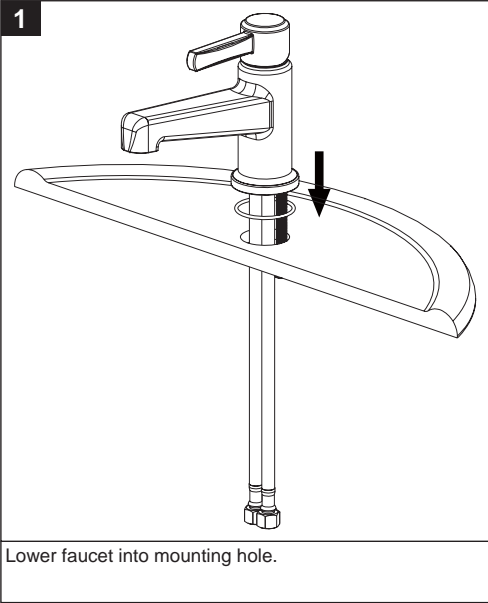

Applicable Standards/Codes

- IAPMO certified to meet or exceed the following:
- ASME A112.18.1/CSA B125.1
 - Uniform Plumbing Code
 - National Plumbing Code of Canada



Installation Dimensions

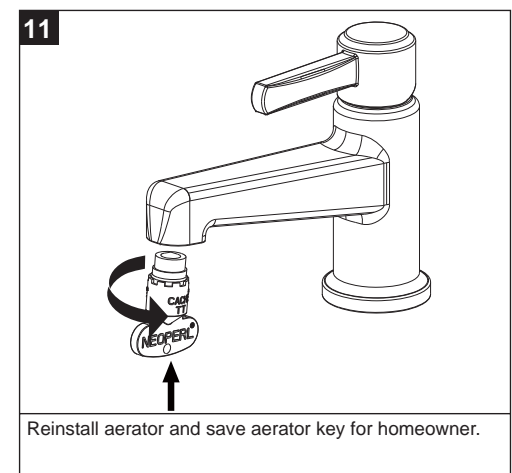
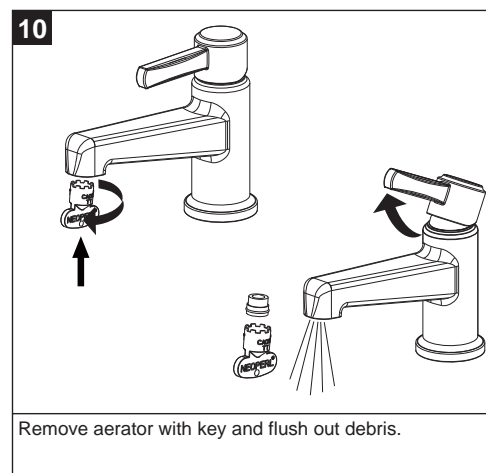
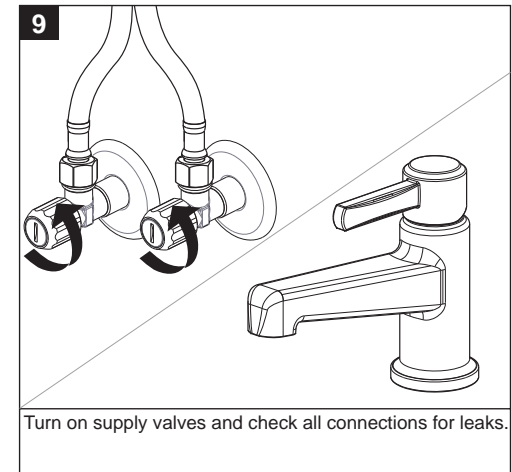
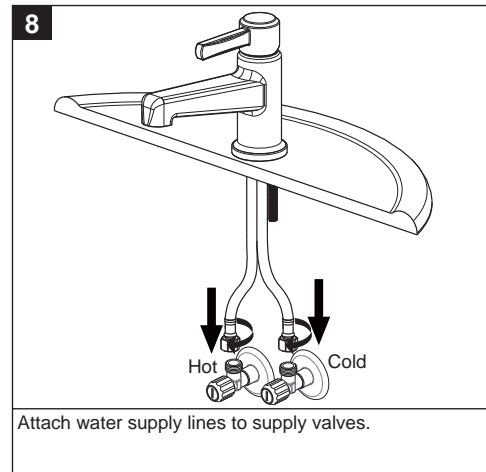
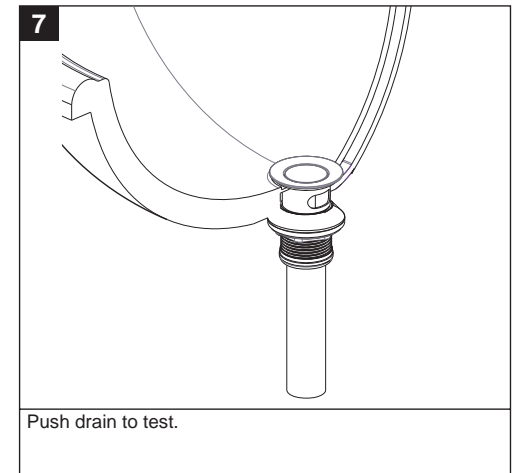
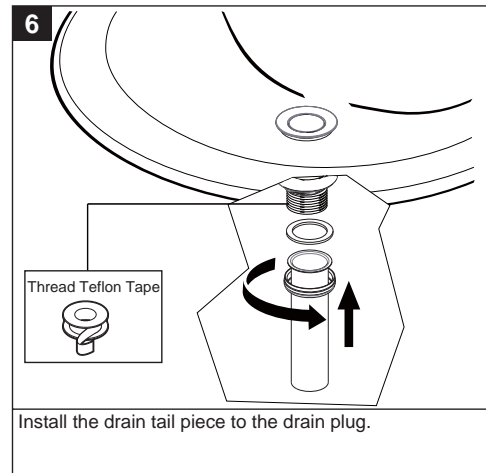
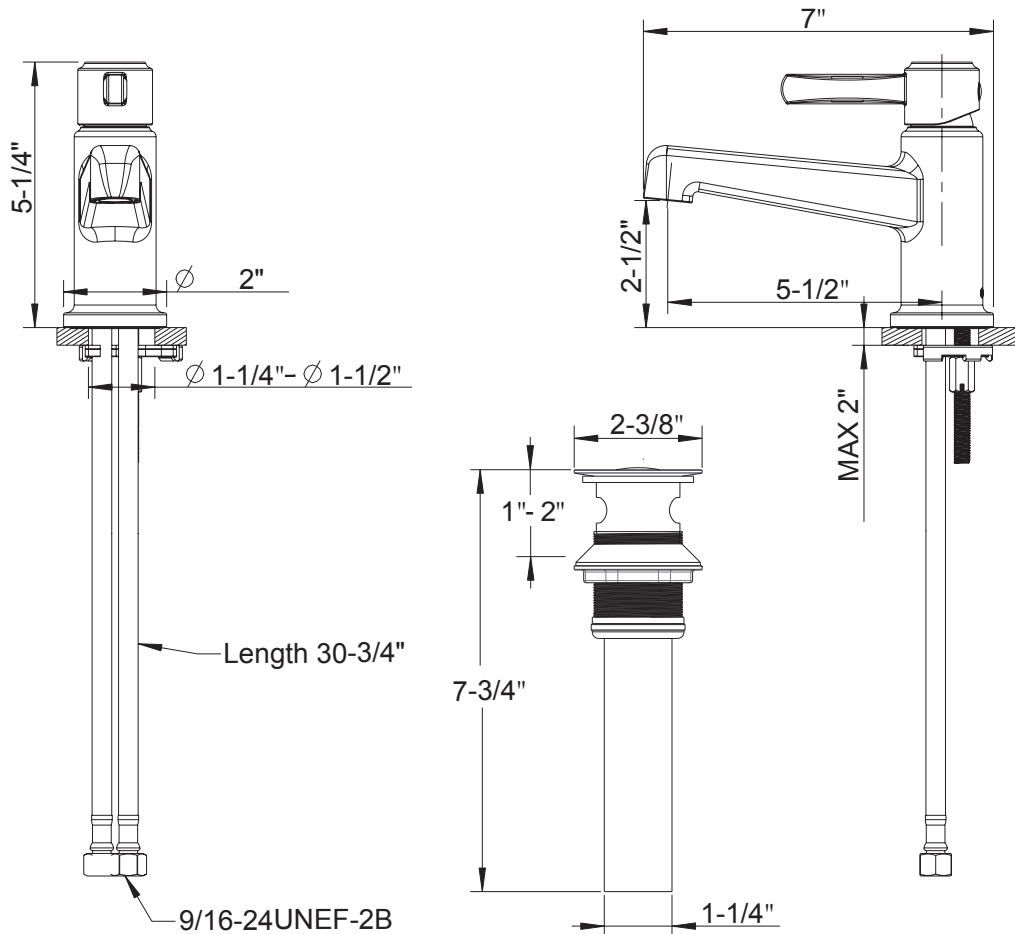

Cleaning Instructions

Rinse away any traces of soap and gently dry with a clean, soft cloth after each use. Rinse completely with water and dry any overspray. This will maintain the finish and avoid water spotting.

To remove mineral deposits, use a 50/50 solution of white vinegar and water. Do not allow the solution to soak on the product.

Simichrome Polish® contains a protective film to enhance maintenance and is helpful in preventing water spot buildup. Follow instructions to ensure optimum results.

Never use an abrasive material such as a brush or scouring pad to clean the surface. The use of abrasive cleaners, cleansers or disinfectants will alter the surface finish and void the warranty.

Do not allow certain materials such as toothpaste, cologne, shaving cream, nail polish remover, vinegar, wine, drain and glass cleaners to remain on the surface. Prolonged contact will alter surface finishes and void the warranty.

We DO NOT recommend using any household cleaners as many can cause damage to the finish.

Please see the website for care instructions for specific finishes.

Trouble-Shooting

If you have followed the instructions and your faucet still does not work properly take these corrective steps.

Problem	Cause	Action
Leaks under spout body	Loose water supply lines	Tighten all connections
Aerator leaks or has an inconsistent water flow pattern	Aerator is dirty or mis-threaded	Remove aerator with key and flush out debris. Reinstall aerator and save aerator key for homeowner
Only hot or only cold water is coming out of the spout	The hot or cold to supply valve is not opened	Open the hot or cold stop valves
Handle will not move	Cartridge is dirty or mis-fitted	Remove, rinse and reinstall cartridge

Warranty - This Crosswater London product is covered by a limited lifetime warranty. For full details, terms and conditions please visit our website.
For further information contact: **Crosswater London**, 393 Fortune Blvd., Milford, MA 01757 www.crosswaterlondon.com
Toll free number: 844-XWATER-1 (844-992-8371) tel: 508-381-0433 fax: 508-381-6068 email: technical@crosswaterlondon.com

Replacement Parts

NO.	Description	Part No.
1	Handle	5C0056900**0
2	Finished Cartridge Dome	5L0P0277
3	Cartridge Nut	5T0C0171NT
4	Cartridge	5D0M0174PL
5	Aerator & Aerator Wrench	9Q252500PL
6	Fixed Assembly	9Q1140NT
7	Push Drain Mounting Hardware	9Q0938NT
8	Push Drain Assembly	5Y0M0196
9	Braided Hose(Hot)	9Q249000CC
10	Braided Hose(Cold)	9Q249100CC
11	Spout O Ring	57001708PL
12	Handle Plug & Screw & Hex Wrench	9Q248900

